

Application Note

CAUTION: The silicon version MS8892A suffers from a design flaw, which prevents the correct operation in autonomous mode (with pin TRIGGER connected permanently to VSS level). This issue will be resolved in version MS8892B in Q4 2021.

1 General product description

The integrated circuit MS8892A is an ultra-low power capacitive sensor specially designed for human body detection and as a wake-up source for ultra-low power systems. It offers two operating modes: meter mode or switch mode. In switch mode the sensor capacitance is compared with the internal reference capacitance. The capacitance threshold can be set absolutely or relative to a baseline value, which is automatically determined and therefore includes fabrication and material tolerances. The MS8892A can optionally be operated with a latching output. In this configuration it can be used as a wake-up device and directly control a power management IC (PMIC) or a PMOS type power switch for achieving the lowest possible consumption in ultra-low power systems. The output stage and latching mode of the MS8892A allow a direct connection to another wake-up source with open-drain output mode, like an RTC, with the output state controlled by the MS8892A. In meter mode the absolute sensor capacitance is measured. The measuring range of the MS8892A covers 200 to 1000fF with a resolution of 8 bits. The configuration of the various options and the operation of the meter mode are controlled via the I²C serial interface. If the configuration is programmed into the non-volatile memory of the MS8892A, it can be operated fully autonomously.

The MS8892A is available in a Quad Flat No leads (QFN) package with a 3 x 3mm foot print, 0.85mm height and 16 pins or in a Chip Scale Package (CSP) with a 1.52 x 1.03mm foot print, 0.64mm height and 12 pins. Both packages can be soldered using a reflow process.

2 Introduction to capacitive sensing

In the MS8892A the capacitive sensor is formed between a driving line (SA) and a receiving line (SB). During the measurement, a rectangular signal is applied to SA and charge is transferred from SA to SB over the attached sensor capacitance CS. The sensor capacitance depends on the print layout, the print material and any material surrounding the SA and SB lines (for instance a device cover). Figure 1 shows the electrical field lines between the driving line SA and the receiving line SB without interference from an object and Figure 2 shows the electrical field lines of the same arrangement when a finger touches the sensor area. The sensor capacitance is lower in Figure 2 because part of the electrical field between the driving line SA and the receiving line SB is shunted

over the body / ground capacitance C_{bg} and back to the device via the device / ground capacitance C_{dg}.

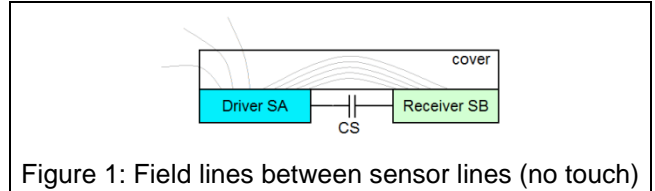

Figure 1: Field lines between sensor lines (no touch)

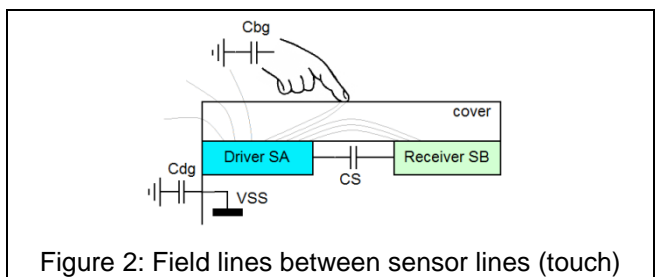

Figure 2: Field lines between sensor lines (touch)

The change in capacitance between «no touch» and «touch» depends on many parameters. For example:

- Sensor layout and architecture
- Cover material and/or print material properties
- Cover and/or print thickness
- Object size (e.g. finger)
- Capacitance of object to ground (e.g. human body)
- Capacitance of device to ground

The influence of the material covering the driving line and the receiving line is expressed by the dielectric constant (or relative permittivity) ϵ_r . Larger ϵ_r values result in higher capacitance values. Typical values for commonly used materials are listed in Table 1.

Table 1: Relative permittivity of commonly used materials at room temperature

Material	ϵ_r
Air	1
Paper	1 to 4
Glass	5 to 10
PMMA (acrylic glass)	3.4
FR2, FR4 (PCB epoxy laminate)	4.3 to 5.4
Skin	42
Water	80

The sensor capacitance depends on the sensor construction and especially on the thickness of the cover. An approaching object can reduce or increase the capacitance between the driving line SA and the

receiving line SB depending on the change of the electrical field lines between SA and SB. Increasing the sensor capacitance is typically related to increasing of the relative permittivity and decreasing the sensor capacitance is typically related to shunting the field lines to ground (Figure 2).

The influence of the cover thickness on the capacitance value is shown in the example in Figure 3. The sensor capacitance («no touch») is increasing nonlinearly as a function of the cover thickness (blue curve). The capacitance value is saturating after approximately 3 to 4 mm. When the cover above the sensor area is touched by an object the capacitance is largest for small thicknesses (e.g. if ϵ_r of a finger is higher than ϵ_r of air). With increasing distance shunting the electrical field lines to ground becomes dominant (for 1mm and higher). There is a certain thickness where both effects are equivalent and no change in capacitance is resulting between «no touch» and «touch». Such a sensor construction has to be avoided for switch mode operation.

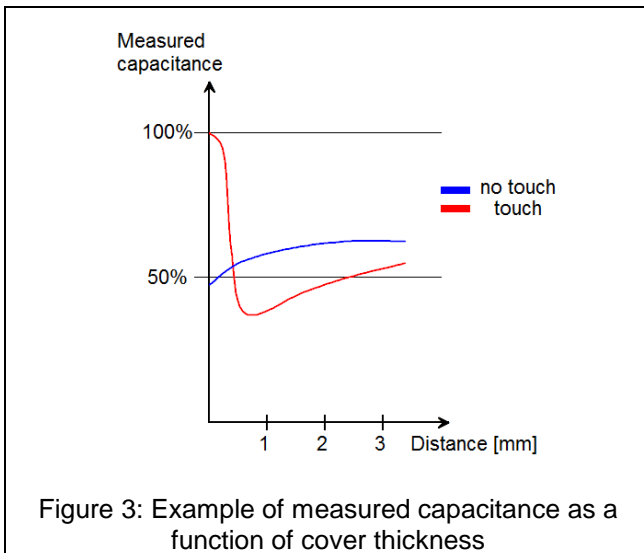

3 Sensor design

Figure 4 shows a basic sensor layout placed on a PCB (e.g. FR4). The following points should be carefully considered in the sensor layout:

1. The receiver line SB has to be shielded from any other dynamic signal by a ground plane between the output SA of the MS8892A and the active sensor area. Any other static signal can be used instead of ground if necessary. The total shielding capacitance must not exceed 5pF.
2. The driving line SA should surround the receiving line SB on the active sensor area.

The sensor capacitance depends on the dimensions of the sensor layout. The following values are meant

as a starting point for a new sensor layout (other values are possible):

- The distance d_s between the driving and the receiving line should be in the order of 0.5 to 3mm.
- The length l_s of the receiving line SB should be in the order of 0.5 to 10mm.

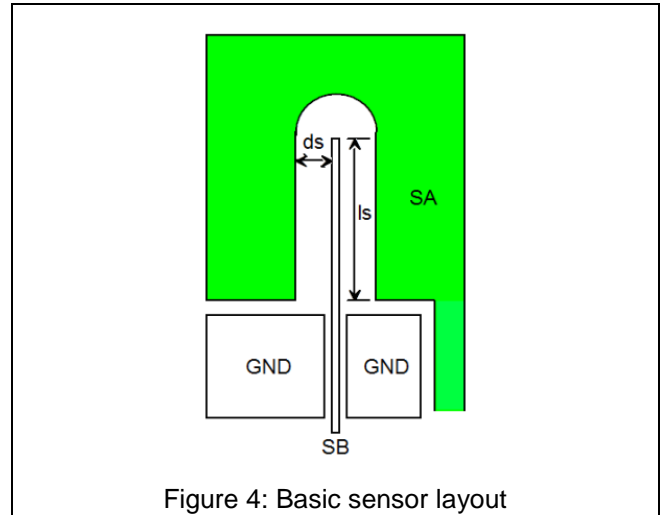

The sensor layout presented in Figure 4 is an example. Other sensor shapes can be realized. Examples of sensor dimensions and corresponding sensor capacitances based on the sensor layout presented in Figure 4 are listed in Table 2.

Table 2: Examples of sensor dimensions and corresponding sensor capacitance values

Distance d_s [mm]	Length l_s [mm]	Approx. sensor capacitance [fF]
2.5	4	160
1.6	4	220
0.6	4	320

Note: These are values for a sensor which is made on an FR4 PCB with 1.6mm thickness, and covered by solder resist.

Often the sensor is placed below a cover (plastic housing, acrylic glass) in the real application. A cover should be attached avoiding air gaps using a glue or sticky foil, or a mechanically rigid construction. Air gaps are not well controlled variable under touch force. This can lead to unwanted capacitance variations.

4 Autonomous operation in switch mode

The MS8892A can be operated autonomously without control of a microcontroller or other trigger sources in switch mode. For this purpose the measuring interval MI needs to be set in the options register OPT1 to

«periodic» or «permanent» measurement followed by programming the setting to the non-volatile memory.

Table 3: Measuring interval options

MI[1:0]	Function
00	single trigger
01	periodic 32 measurements per second
10	periodic 8 measurements per second
11	periodic 2 measurements per second

Also the threshold capacitance value CTH and the other options in registers OPT1 and OPT2 must be defined and programmed to the non-volatile memory for autonomous operation in switch mode. In addition pin TRIGGER must be connected to VSS.

5 Effects of electro-magnetic interference

The sensor input line SB behaves like an antenna with a high input resistance in active mode. A surrounding electromagnetic field (EMF) can be collected at the antenna and interfere with the capacitance measurement. Interference by an EMF can be measured in meter mode. For reliable operation in switch mode, the threshold level needs to be set with sufficient margin to the interference. The source of interference by EMF can be internal (e.g. microcontroller) or external (e.g. fluorescent lamp). Proper shielding of the receiver line SB will minimize internal interference. Proper shielding can be achieved with a ground plane surrounding the receiver line SB. The total shielding capacitance should not exceed 5pF. External shielding is difficult since the sensor area has to be exposed. A small sensor area will help to minimize interference from an external EMF.

6 Threshold calibration strategy for switch mode operation

6.1 Quick start

In most real application situations the capacitance variation between *no-touch* and *touch* state amounts to more than 10 counts and the capacitance value when touched is smaller. Therefore, a quick start setup can be achieved with the relative threshold mode using a fixed threshold step size of -10.

1. Acquire the baseline capacitance in *no-touch* state by sending command MCS (or by a short pulse on the INIT pin)
2. Select the relative threshold mode and RAM mode in register OPT2

3. Set the threshold register RTH to 0x0A (negative step, height 10)
4. Select one of the periodic switch mode measurement settings and keep the default filter setting in register OPT1

At this time the MS8892A is reacting on touch events which can be observed on the output OUT. The switching behavior can be optimized by adjusting the relative threshold value, the filter settings, and the measurement rate.

6.2 Optimised absolute threshold

To obtain an optimized threshold value, measurements of the capacitance in *no-touch* and *touch* state are required. The threshold value must be set between the two values, ideally halfway between the *touch* and *no-touch* values. If the difference between *no-touch* and *touch* capacitance is large, the switching behavior can be influenced by tuning the threshold up/down. A safety margin of several counts must be kept between the threshold and the *no-touch* or *touch* capacitance value.

If the fabrication and material tolerances are small, the absolute threshold can have a fixed value for a single product. If the tolerances are larger, a threshold calibration per device may be necessary. In this situation the relative threshold mode can simplify the calibration, as described in the following section.

6.3 Optimised relative threshold

The capacitance difference obtained between the *no-touch* and *touch* states is usually fairly constant for a given application, even if the fabrication and material tolerances don't allow a fixed threshold setting. In this case, using the relative threshold mode allows setting a robust threshold without the need to determine an individual threshold per device.

The capacitance difference between *no-touch* and *touch* state has to be obtained just once for a given application. Based on this value, the threshold step height can be estimated, further optimized and then used throughout the production for all devices. In turn, the relative threshold mode requires one threshold baseline measurement after power-up of the MS8892A. In autonomous operation mode (TRIGGER = 0), the first measurement after (1) power-up, (2) an RSTN reset or (3) a short pulse on INIT will be baseline measurement. In I²C controlled mode, the baseline measurement can still be triggered with (1) an INIT pulse or (2) by an MCS measurement command.

7 Evaluation board

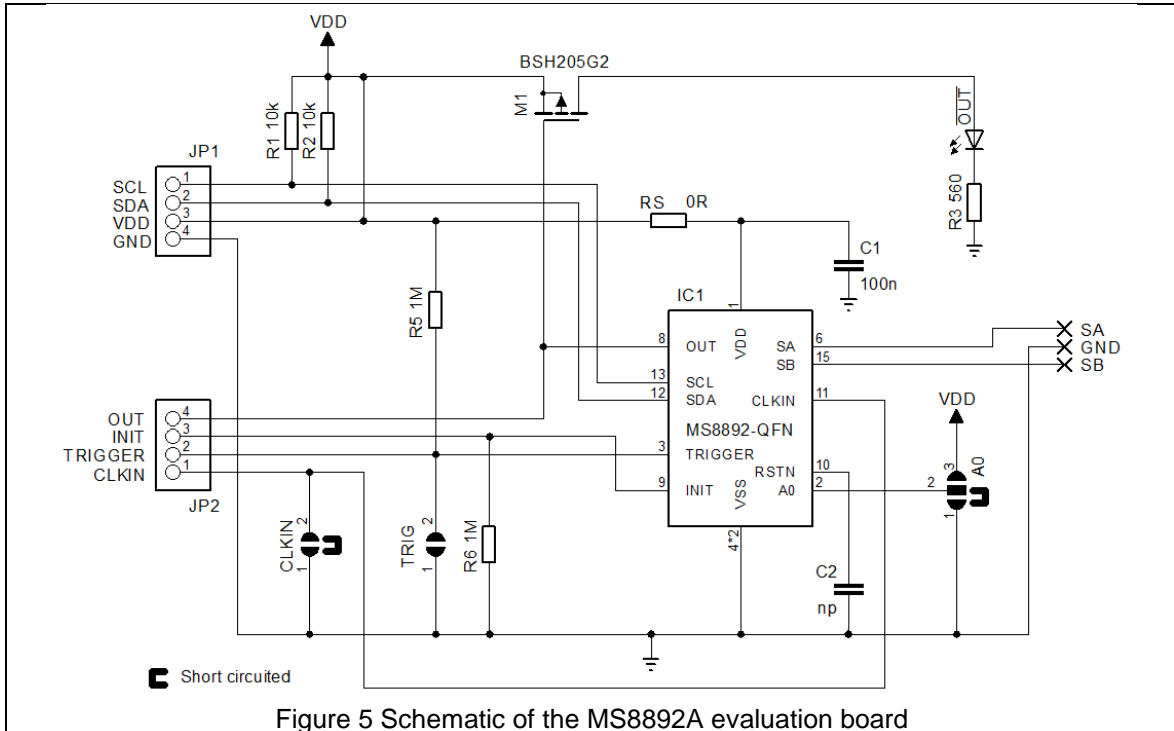

Figure 5 Schematic of the MS8892A evaluation board

The schematic of the evaluation board is shown in Figure 5. Most of the MS8892A signals are available on three connectors JP1, JP2 and JP3. The pinning of the three connectors is given in Table 4. The I²C address input A0 is initially soldered to VSS on the backside of the evaluation board. This connection can be easily removed and soldered to VDD to enable the alternate I²C address. The pin TRIGGER is pulled to VDD level by R5. This allows to control TRIGGER from a microcontroller. TRIGGER can also be soldered to VSS level permanently for autonomous operation using a solder bridge on the backside of the board. The input CLKIN is initially soldered to VSS on the backside of the board. If an external clock should be applied to CLKIN, this solder connection can easily be removed. The input INIT is pulled to VSS level by R6. It can be controlled from a microcontroller or a pulse generator for testing the functionality. The output OUT is controlling a PMOS transistor which switches a light-emitting diode (OUT). The diode shows the result of the compare measurement in switch mode. The PMOS switch and LED represent a system with a power switch directly controlled by the MS8892A. The MS8892A soldered to the evaluation board is not configured. Configuration of the operation mode options and the threshold capacitance has to be done via the I²C serial interface connected to connector JP1. Programming the configured values into the non-volatile memory of the MS8892A is possible. Details on how to program the non-volatile memory are given in section 10 “OTP Memory” of the datasheet.

Table 4: Connectors on the evaluation board

Pin	JP1	JP2	JP3
1	SCL	CLKIN	SB
2	SDA	TRIGGER	GND (VSS)
3	VDD	INIT	SA
4	GND (VSS)	OUT	

Figure 6 shows the top side of the assembled evaluation board. The two connectors JP1 and JP2 are located on the lower side and connector JP3 is located on the upper side of the evaluation board. Pin 1 of connectors JP1, JP2 are marked with a large white dot (●) located next to it.

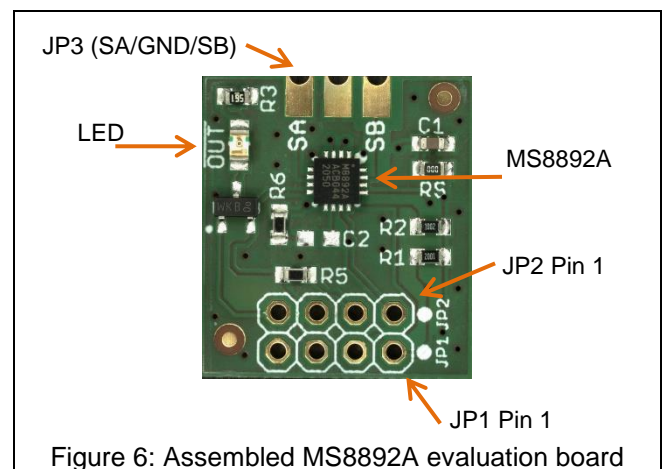

Figure 6: Assembled MS8892A evaluation board

Figure 7 shows the bottom side of the evaluation board. The three highlighted areas show the solder options of the signals TRIGGER (TRIG), CLKIN and A0.

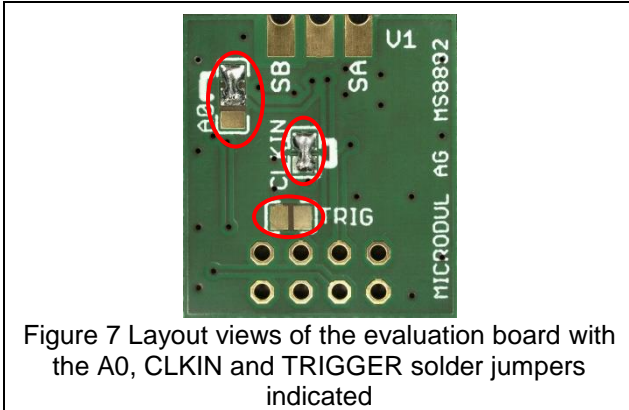

Figure 7 Layout views of the evaluation board with the A0, CLKIN and TRIGGER solder jumpers indicated

The evaluation board allows testing of the main features as a system power controller, including the

- Relative threshold mode, including the baseline measurement using an I²C command or the INIT pin
- The output latching mode, including the latch clearing using an I²C command or the INIT pin
- The control of a system power switch, modeled by the PMOS M1 and the LED OUT
- The connection to an external RTC for combined control of the power switch via the signal OUT and the extremely low power consumption when supplying the clock to CLKIN of the MS8892A

These possibilities are described with more detail in section 11.2 of the MS8892A datasheet.

In order to get started quickly with the evaluation of the MS8892A on the evaluation board, a sample sensor board is included in the kit which can be directly soldered to the evaluation board or connected with standard 100mil headers. Adding a plex-glass overlay of 1-2 mm thickness on top of the sensor area is suggested. Without it, directly touching the sensor may show some unwanted on/off switching (due to excessive capacitive loading on SB).

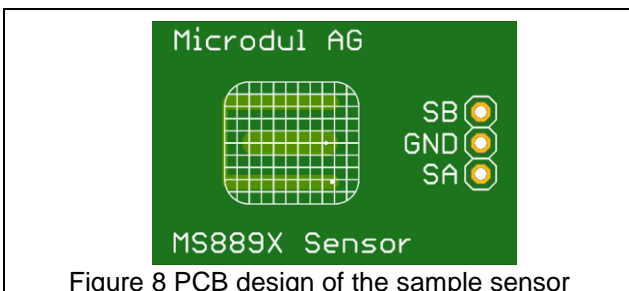

Figure 8 PCB design of the sample sensor

As an alternative to the sensor PCB, simply attach two wires of 20-50 mm length to SA and SB to get started. The wires can be formed as desired, as long as the allowed capacitance of 1000 fF between SA and SB is not exceeded.

8 Coding requirements & examples

8.1 Coding requirements

Waiting time after COMP or MCS commands

The COMP or MCS commands trigger measurements with a duration of up to 1 ms. In order not to interfere with the measurement, a waiting time of ≥ 2 ms is suggested before sending the next command to the MS8892A.

Measurements during periodic mode

Measurements using I²C commands (MCS, COMP) are **not executed** when the MS8892A is in periodic measurement mode (MI \neq '00' or TRIGGER = 0). The CVAL register will not be updated, and reading CVAL (RCS command) will return the previous value. Other I²C commands will function normally.

8.2 Arduino code example

The following code is an example which runs on the Arduino platform. It configures the MS8892A in periodic switching mode using a relative threshold configuration to automatically adapt to the actual baseline capacitance of the attached sensor.

The example source code can be downloaded from the Microdul web page:

<https://www.microdul.com/en/ultra-low-power-sensors/human-body-detector/>

I²C address and command definitions:

```
#define MS8892_ADDR 0x24

#define MCS 0x00
#define RCS 0x01
#define COMP 0x02
#define RRES 0x03
#define LCLR 0x04
#define WTH 0x05
#define RTH 0x06
#define WOPT1 0x07
#define WOPT2 0x09
```

Configuration of the MS8892A for periodic comparison operation in relative threshold mode, including a capacitance measurement to determine the threshold baseline. It is important to add a small delay ≥ 2 ms after the measurement command MCS to let the measurement complete before changing the MS8892A configuration or reading the measurement value:

```
void setup() {
  Wire.begin();
  Serial.begin(115200);

  // set RAM Mode, invert polarity, rel. threshold
  write_data(MS8892_ADDR, WOPT2, 0b01001001);
  // set relative threshold step -10
  write_data(MS8892_ADDR, WTH, 10);
  // measure capacitance as threshold baseline
  write_command(MS8892_ADDR, MCS); delay(2);
  // set periodic comparison mode with 8 measurements/s
  write_data(MS8892_ADDR, WOPT1, 0b00001000);
}
```

The main loop simply lets the Arduino board LED flash every 2 seconds (heartbeat):

```
void loop() {
  // 2s heartbeat flashes on Arduino LED
  digitalWrite(LED_BUILTIN, HIGH);
  delay(100);
  digitalWrite(LED_BUILTIN, LOW);
  delay(1900);
}
```

The following subroutines simplify the I²C access to the MS8892A:

```
/* I2C access routines
******/

void write_data(int address, int command, int databyte)
{
  Wire.beginTransmission(address);
  Wire.write(command);
  Wire.write(databyte);
  Wire.endTransmission();
}

int read_data(int address, int command)
{
  int value = 0;

  Wire.beginTransmission(address);
  Wire.write(command);
  Wire.endTransmission(false);
  Wire.requestFrom(address, 1);
  value = Wire.read();
  return (value);
}

void write_command(int address, int command)
{
  Wire.beginTransmission(address);
  Wire.write(command);
  Wire.endTransmission(true);
}
```

9 ESD

Inputs and outputs are protected against electrostatic discharge during normal operation. However to be totally safe, it is advisable to undertake precautions appropriate to handling MOS devices in all process steps.

10 Disclaimer

Whilst every effort is taken to make sure that the information contained in this document is correct, Microdul AG accepts no liability whatsoever for the accuracy or completeness of the information given. Microdul AG reserves the right to change or correct information without prior notice as necessary.

11 Ordering information

For ordering MS8892A samples and the MS8892 evaluation board, please contact:

semiconductors@microdul.com